

## FITTING INSTRUCTION

Clamp mark in acc. with		Cables joining
ISO	PN	
1	L	Left directional lights
2	+	Rear fog lights
3	31	Ground
4	R	Right directional lights
5	58R	Right side parking lights
6	54	Stoptlights
7	58L	Left side parking lights

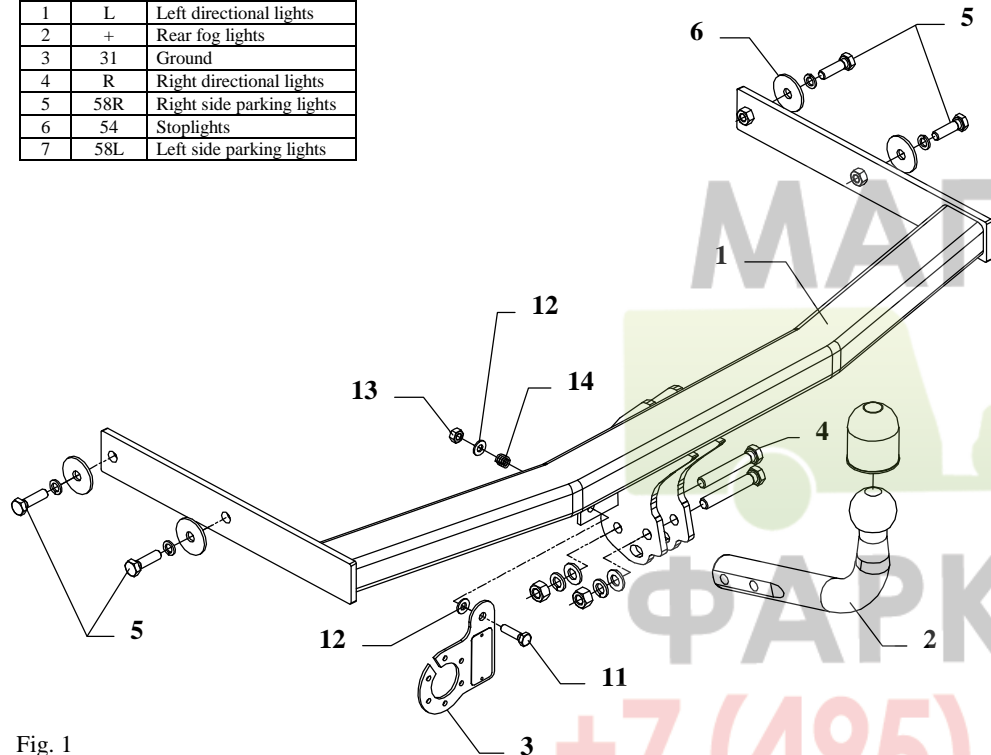

Fig. 1

This towbar is designed to assembly in following cars: **SKODA FABIA 4 door**, produced since 2001 till 03.2007 and **SKODA FABIA ESTATE** produced since 2001 till 03.2007 and since 2008, catalogue no. **H12** and is prepared to tow trailers max total weight **1000 kg** and max vertical mass **50 kg**.

### From manufacturer

Thank you for buying our product. Their reliability has been confirmed in many tests. Reliability of towbar depends also on correct assembly and right operation. For this reasons we kindly ask to read carefully this instruction and apply to hints.

*The towbar should be installing in points described by a car producer.*

## The instruction of the assembly

1. Remove the rear bumper and a metal support of bumper (this metal part will not be used any more).
2. Find two holes at the bottom of the car next to a chassis under the conservation layer.
3. Slide the main bar of the towbar (pos. 1) into the chassis and then fix with M10x35mm (pos. 5) bolts with washers (pos. 6) from the towbar accessories.
4. Position the ball of towbar (pos. 2) and fix with M12x75mm (pos. 5) bolts from the towbar accessories.
5. Fix socket plate (pos. 3) according to figure 1.
6. Cut out the bumper according to fig. 2 and mount it to the car.

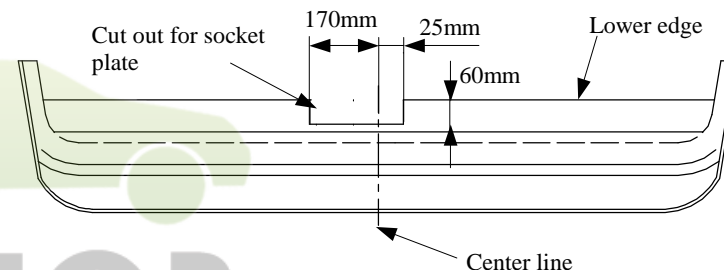

Fig. 2 Bumper cut out (top view)

7. Tighten all nuts and bolts according the torque shown in the table.
8. Connect electric wires of 7-poles socket according to the instruction of the car. (Recommend to make at authorized service station).
9. Complete the paint cover of towbar (during the mounting paint cover could be destroyed).

Torque settings for nuts and bolts (8,8):	
M 8 - 25 Nm	M 10 - 55 Nm
M 12 - 85 Nm	M 14 - 135 Nm











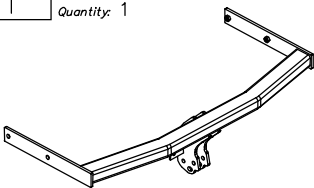

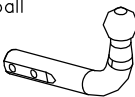

### NOTE

After install the towbar you should get adequate note in registration book (at authorised service station).The car should be equipped with:

- Indicators
- Tow mirrors

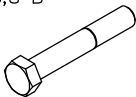
Check all bolts and nuts after 1000km of exploitation. The ball of towbar must be always kept clear and conserve with a grease.

## Towbar equipment:

Pos. 1 Name: Main bar Quantity: 1 	Pos. 5 Name: Bolt 8,8 B Quantity: 4 Dim.: M10x35mm 	Pos. 10 Name: Spring washer Quantity: 4 Dim.: Ø 10,2 mm 
	Pos. 6 Name: Washer Quantity: 4 Dim.: Ø42xØ12x3mm 	Pos. 11 Name: Bolt 8,8 B Quantity: 1 Dim.: M8x30mm 
Pos. 2 Name: Tow ball Quantity: 1 	Pos. 7 Name: Nut 8 B Quantity: 2 Dim.: M12 	Pos. 12 Name: Plain washer Quantity: 2 Dim.: Ø 8,5 mm 
Pos. 3 Name: Socket plate Quantity: 1 	Pos. 8 Name: Plain washer Quantity: 2 Dim.: Ø 13 mm 	Pos. 13 Name: Nut 8 B Quantity: 1 Dim.: M8 
Pos. 4 Name: Bolt 8,8 B Quantity: 2 Dim.: M12x75mm 	Pos. 9 Name: Spring washer Quantity: 2 Dim.: Ø 12,2 mm 	Pos. 14 Name: Spring Quantity: 1 
		Pos. 15 Name: Ball cover Quantity: 1 



**PPUH AUTO-HAK S.J.**

Produkcja Zaczepów Kulowych  
Henryk & Zbigniew Nejman  
76-200 SŁUPSK ul. Słoneczna 16K  
tel/fax (059) 8-414-414; 8-414-413  
email: [office@autohak.com.pl](mailto:office@autohak.com.pl)  
[www.autohak.com.pl](http://www.autohak.com.pl)

## Towing hitch (without electrical set)

Class: **A50-X** Cat. no. **H12**

Designed for:

Manufacturer: **SKODA**

Model: **FABIA**

Type: **4 door**

produced since 2001 till 03.2007 and

Type: **ESTATE**

produced since 2001 till 03.2007

and produced since 2008

Approval number acc. to regulations EKG/ONZ 55.01: **E20-55R-01 0677**

Technical data:

**D-value: 6,17 kN**

maximum trailer weight: **1000 kg**

maximum vertical cup mass: **50 kg**

**+7 (495) 6-693-693**

## Foreword

This towbar is designed according to rules of safety traffic regulations. The towing hitch is a safety component and can be install only by qualified personnel. Any alteration or conversion of the towing hitch is prohibited and would lead to cancellation of design certification. Remove insulating compound and underseal from vehicle (if present) in the area of the matting surfaces of the towing hitch.

The vehicle manufacturer's specifications regarding trailer load and max. vertical cup load are decisive for driving, and values for the towing hitch cannot be exceeded.

*D-value formula:*

$$\frac{\text{Max trailer weight [kg]} \times \text{Max vehicle weight [kg]}}{\text{Max trailer weight [kg]} + \text{Max vehicle weight [kg]}} \times \frac{9,81}{1000} = D \text{ [kN]}$$